

锂离子电芯规格书

Specification For Lithium-ion Rechargeable Cell

电芯型号 : N18650CP

Cell Type : N18650CP

Document No	P/PR03/PB-D-N18650CP-ZZ-SP	Revised date	2021-01-28
Version	A/02	Pages	14
Approved	Checked	Designed	
Yanbin Li	Huajie Song	Xianwen Yi	李芝文





Contents

目录

1	Preface 前言	1
2	Definition 定义.....	1
2.1	Standard charge method 标准充电方式.....	1
2.2	Standard discharge method 标准放电方式	1
2.3	Nominal capacity 标称容量	1
3	Cell model and dimensions 电芯型号及尺寸	1
3.1	Description and model 电芯说明及型号	1
3.2	Cell dimensions 电芯尺寸.....	1
4	Cell characteristics 电芯特性	2
5	Technical requirements 技术要求	3
5.1	Cell operating conditions 电芯使用环境	3
5.2	Cell testing conditions 电芯试验环境.....	3
5.3	Requirement of the testing equipment 测量仪表要求	3
5.4	Electrochemical characteristics 电化学特性.....	3
5.5	Environmental and safety characteristics 环境适应性能和安全性能.....	6
6	Package picture 包装图片	9
7	Shipment 出货	9
8	Warranty 质量保证.....	9
9	Storage and shipment requirement 存储及运输要求.....	10
10	Warning and cautions in handling the lithium-ion cell 电芯使用时警告事项及注意事项	10
11	Restriction of hazardous substances 有害物质控制要求	13
12	Contact information 联系方式	13
13	Revision history 修订履历	14

Document No	P/PR03/PB-D-N18650CP-ZZ-SP	Version	A/02	Page	1 / 14
-------------	----------------------------	---------	------	------	--------

1 Preface 前言

This specification describes the type, dimension, performance, technical characteristics, warnings and cautions of the lithium ion rechargeable cell. The specification only applies to N18650CP cell supplied by Zhengzhou BAK Battery Co., Ltd.

本标准描述了圆柱型锂离子电芯的外型尺寸、特性、技术要求及注意事项。本标准适用于郑州比克电池有限公司生产的圆柱型 N18650CP 锂离子电芯。

2 Definition 定义

2.1 Standard charge method 标准充电方式

At 25 ± 2 °C, the cell is charged to 4.2 V at constant current of 0.5 C (1625 mA), then charged at constant voltage of 4.2 V until the current tapers to $\leq 0.01C$ (32 mA) followed by resting for 5min.

在 25 ± 2 °C 下, 电芯以 0.5C (1625 mA) 恒流充电至 4.2 V 后, 以 4.2 V 恒压充电至电流小于等于 0.01C (32mA), 静置 5min。

2.2 Standard discharge method 标准放电方式

Under 25 ± 2 °C, the cell is discharged to 2.5V at a constant current of 0.2C (650 mA).

指在 25 ± 2 °C 环境下, 电芯以 0.2C (650 mA) 恒流放电至 2.5 V。

2.3 Nominal capacity 标称容量

Nominal capacity, signed as capacity and using mAh as unit, is obtained by discharging a cell via standard discharge method after it is standard charged.

电芯标称容量以 Cap 表示, 单位为毫安时 (mAh), 是指电芯按标准充电方式充电后, 按标准放电方式放电得到的容量。

3 Cell model and dimensions 电芯型号及尺寸

3.1 Description and model 电芯说明及型号

Description: Cylindrical Li-ion rechargeable cell

说明: 圆柱型锂离子二次电芯

Model: N18650CP

型号: N18650CP

3.2 Cell dimensions 电芯尺寸

Cell physical dimensions listed in Figure 1 (unit: mm), with tube.

电芯尺寸示意图如图 1 所示 (单位: mm), 带热缩膜。

Document No	P/PR03/PB-D-N18650CP-ZZ-SP	Version	A/02	Page	2 /14
-------------	----------------------------	---------	------	------	-------

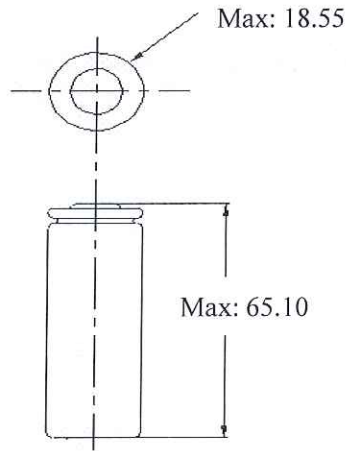

Figure 1/ 图 1

4 Cell characteristics 电芯特性

Unless otherwise specified, the cell is fresh cell and tested by standard charge and standard discharge.

除非有特殊说明，否则所有样品均为新鲜电芯，且按标准充电和标准放电方式进行测试。

ITEM 项目		SPECIFICATION 规格
Capacity 容量	Nominal capacity 标称容量	3350mAh by standard charge and discharge 以标准充放电制式进行充放电，标称容量为 3350mAh
	Minimum capacity 最小容量	3250mAh by standard charge and discharge 以标准充放电制式进行充放电，最小容量为 3250mAh
Nominal voltage 标称电压		3.6 V
Charge cut-off voltage 充电终止电压		4.20 V
Discharge cut-off voltage 放电终止电压		2.50 V
Max charge current 最大充电电流		1C (25°C, not for cycle life 不支持循环)
Max discharge current 最大放电电流		3C (25°C, not for cycle life 不支持循环)
Storage temperature 存储温度		1 year: -20~25 °C (1 年: -20~25 °C) 3 months: -20~45 °C (3 个月: -20~45 °C) 1 month: -20~60 °C (1 个月: -20~60 °C)
Humidity range 湿度范围		0 ~ 60% RH (non-condensing) 0 ~ 60% RH (不冷凝)

This spec manual is the enterprise standard of ZhengZhou BAK Battery Co., Ltd. Without authorization, any pirate or circulation is prohibited.

本规格书为郑州比克电池有限公司企业标准，未经授权，禁止翻印、传播。

Document No	P/PR03/PB-D-N18650CP-ZZ-SP	Version	A/02	Page	3 /14
--------------------	----------------------------	----------------	------	-------------	-------

Internal resistance 内阻	≤ 35 mΩ(AC Impedance, 1000 Hz) 交流阻抗测量频率为 1000 Hz, 交流内阻≤ 35 mΩ
Weight 重量	≤ 49g

5 Technical requirements 技术要求

5.1 Cell operating conditions 电芯使用环境

Charge temperature 充电温度: 0 ~ 45 °C

Discharge temperature 放电温度: -20 ~ 60 °C

5.2 Cell testing conditions 电芯试验环境

Unless otherwise specified, all tests stated should be done at 25 ± 2 °C.

除非有特殊说明, 所有测试须在 25 ± 2 °C 下进行。

5.3 Requirement of the testing equipment 测量仪表要求

The voltage measurement device: not less than 0.5 grade

电压测量装置: 不低于 0.5 级

The current measurement device: not less than 0.5 grade

电流测量装置: 不低于 0.5 级

AC Impedance: 1000 Hz

交流阻抗测量频率: 1000 Hz

Temperature meter: precision ≤ 0.5 °C

温度仪表要求: 测量温度的仪表精度不高于 0.5°C

时间测量装置: ± 0.1%

The size measurement device: ± 0.1%

尺寸测量装置: ± 0.1%

The quality measurement device: ± 0.1%

质量测量装置: ± 0.1%

5.4 Electrochemical characteristics 电化学特性

Unless otherwise specified, the cell should be fresh cell and tested by standard charge and discharge.

除非有特殊说明, 否则所有测试要求为: 温度在 25±2°C 条件下, 样品为新鲜电池, 充放电制度为标准充电和标准放电。

Document No	P/PR03/PB-D-N18650CP-ZZ-SP	Version	A/02	Page	4 / 14
-------------	----------------------------	---------	------	------	--------

No. 序号	Item 测试项目	Test method and conditions 测试方法与条件	Criterion 性能标准												
5.4.1	Rate discharge capability 倍率放电性能	(1) Charge: 0.5C constant current charge to 4.2V followed by 4.2V constant voltage charge to cut-off current $\leq 0.01C$; (2) Discharge: 0.2C, 0.5C, 1C, 2C, 3C constant current discharge to cut-off voltage $\leq 2.5V$. (1) 充电: 以 0.5C 恒流充电至 4.2V 后, 以 4.2V 恒压充电至电流 $\leq 0.01C$; (2) 放电: 以 0.2C, 0.5C, 1C, 2C, 3C 恒流放电至截止电压 $\leq 2.5V$ 。	<table border="1"> <thead> <tr> <th>Current 电流</th> <th>Relative Capacity 相对容量比</th> </tr> </thead> <tbody> <tr> <td>0.2C</td> <td>100%</td> </tr> <tr> <td>0.5C</td> <td>$\geq 96\%$</td> </tr> <tr> <td>1C</td> <td>$\geq 93\%$</td> </tr> <tr> <td>2C</td> <td>$\geq 90\%$</td> </tr> <tr> <td>3C</td> <td>$\geq 88\%$</td> </tr> </tbody> </table>	Current 电流	Relative Capacity 相对容量比	0.2C	100%	0.5C	$\geq 96\%$	1C	$\geq 93\%$	2C	$\geq 90\%$	3C	$\geq 88\%$
Current 电流	Relative Capacity 相对容量比														
0.2C	100%														
0.5C	$\geq 96\%$														
1C	$\geq 93\%$														
2C	$\geq 90\%$														
3C	$\geq 88\%$														
5.4.2	RT cycle life 常温循环寿命	(1) Charge: 0.5C constant current charge to 4.2V followed by 4.2V constant voltage charge to cut-off current $\leq 0.01C$ (32 mA); (2) Discharge: 1C constant current discharge to cut-off voltage $\leq 2.75V$. (1) 充电: 以 0.5C 恒流充电至 4.2V 后, 以 4.2V 恒压充电至电流 $\leq 0.01C$ (32 mA); (2) 放电: 以 1C 恒流放电至截止电压 $\leq 2.75V$ 。	$\frac{\text{Discharge capacity of 801th cycle}}{\text{Original discharge capacity}} \geq 80\%$ $\frac{\text{第801次循环的放电容量}}{\text{初始放电容量}} \geq 80\%$												

Document No	P/PR03/PB-D-N18650CP-ZZ-SP	Version	A/02	Page	5 / 14
-------------	----------------------------	---------	------	------	--------

5.4.3	High-low temperature discharge performance 高低温放电性能	<p>(1) Charge: 0.5C constant current charge to 4.2V followed by 4.2V constant voltage charge to cut-off current $\leq 0.01C$ at $25\pm 2^\circ C$;</p> <p>(2) Discharge: 0.2C constant current discharge to cut-off voltage $\leq 2.5V$ at $25^\circ C, 60^\circ C, 45^\circ C, 10^\circ C, 0^\circ C, -10^\circ C, -20^\circ C$.</p> <p>(1) 充电: $25\pm 2^\circ C$下, 以 0.5C 恒流充电至 4.2V 后, 以 4.2V 恒压充电至电流$\leq 0.01C$;</p> <p>(2) 放电: 在 $25^\circ C, 60^\circ C, 45^\circ C, 10^\circ C, 0^\circ C, -10^\circ C, -20^\circ C$下以 0.2C 恒流放电至截止电压$\leq 2.5V$。</p>	<table border="1"> <thead> <tr> <th>Temperature 温度</th> <th>Relative Capacity 相对容量比</th> </tr> </thead> <tbody> <tr> <td>25°C</td> <td>100%</td> </tr> <tr> <td>60°C</td> <td>$\geq 95\%$</td> </tr> <tr> <td>45°C</td> <td>$\geq 95\%$</td> </tr> <tr> <td>10°C</td> <td>$\geq 88\%$</td> </tr> <tr> <td>0°C</td> <td>$\geq 85\%$</td> </tr> <tr> <td>-10°C</td> <td>$\geq 75\%$</td> </tr> <tr> <td>-20°C</td> <td>$\geq 70\%$</td> </tr> </tbody> </table>	Temperature 温度	Relative Capacity 相对容量比	25°C	100%	60°C	$\geq 95\%$	45°C	$\geq 95\%$	10°C	$\geq 88\%$	0°C	$\geq 85\%$	-10°C	$\geq 75\%$	-20°C	$\geq 70\%$
Temperature 温度	Relative Capacity 相对容量比																		
25°C	100%																		
60°C	$\geq 95\%$																		
45°C	$\geq 95\%$																		
10°C	$\geq 88\%$																		
0°C	$\geq 85\%$																		
-10°C	$\geq 75\%$																		
-20°C	$\geq 70\%$																		
5.4.4	Storage performance at $25^\circ C$ (100% SOC) $25^\circ C$ 满电存储性能	<p>(1) Charge: 0.5C constant current charge to 4.2V followed by 4.2V constant voltage charge to cut-off current $\leq 0.01C$; Discharge: 0.2C constant current discharge to cut-off voltage $\leq 2.5V$, to obtain the initial capacity;</p> <p>(2) Charge: 0.5C constant current charge to 4.2V followed by 4.2V constant voltage charge to cut-off current $\leq 0.01C$;</p> <p>(3) Stored at $25 \pm 2^\circ C$ for 28 days;</p> <p>(4) Discharge: 0.2C constant current discharge to cut-off voltage $\leq 2.5V$, to obtain the residual capacity;</p> <p>(5) Charge: 0.5C constant current charge to 4.2V followed by 4.2V constant voltage charge to cut-off current $\leq 0.01C$; Discharge: 0.2C constant current discharge to cut-off voltage $\leq 2.5V$, to obtain the recovery capacity.</p> <p>(1) 充电: 以 0.5C 恒流充电至 4.2V 后, 以 4.2V 恒压充电至电流$\leq 0.01C$; 放电: 以 0.2C 恒流放电至截止电压$\leq 2.5V$, 获得初始容量;</p> <p>(2) 充电: 以 0.5C 恒流充电至 4.2V 后, 以 4.2V 恒压充电至电流$\leq 0.01C$;</p> <p>(3) 于 $25 \pm 2^\circ C$下存储 28 天;</p> <p>(4) 放电: 以 0.2C 恒流放电至截止电压$\leq 2.5V$, 获得残余容量;</p> <p>(5) 充电: 以 0.5C 恒流充电至 4.2V 后, 以 4.2V 恒压充电至电流$\leq 0.01C$; 放电: 以 0.2C 恒流放电至截止电压$\leq 2.5V$, 获得恢复容量。</p>	<table border="1"> <thead> <tr> <th>Capacity 容量</th> <th>Relative Capacity 相对容量比</th> </tr> </thead> <tbody> <tr> <td>Residual capacity 残余容量</td> <td>$\geq 90\%$</td> </tr> <tr> <td>Recovery capacity 恢复容量</td> <td>$\geq 95\%$</td> </tr> <tr> <td>Initial capacity 初始容量</td> <td>100%</td> </tr> </tbody> </table>	Capacity 容量	Relative Capacity 相对容量比	Residual capacity 残余容量	$\geq 90\%$	Recovery capacity 恢复容量	$\geq 95\%$	Initial capacity 初始容量	100%								
Capacity 容量	Relative Capacity 相对容量比																		
Residual capacity 残余容量	$\geq 90\%$																		
Recovery capacity 恢复容量	$\geq 95\%$																		
Initial capacity 初始容量	100%																		

Document No	P/PR03/PB-D-N18650CP-ZZ-SP	Version	A/02	Page	6/14
-------------	----------------------------	---------	------	------	------

5.4.5	Storage performance at 60°C (100% SOC) 60°C 满电存储性能	<p>(1) Charge: 0.5C constant current charge to 4.2V followed by 4.2V constant voltage charge to cut-off current $\leq 0.01C$ at $25\pm 2^\circ C$; Discharge: 0.2C constant current discharge to cut-off voltage $\leq 2.5V$ at $25\pm 2^\circ C$, to obtain the initial capacity;</p> <p>(2) Charge: 0.5C constant current charge to 4.2V followed by 4.2V constant voltage charge to cut-off current $\leq 0.01C$ at $25\pm 2^\circ C$;</p> <p>(3) Stored at $60 \pm 2^\circ C$ for 7 days;</p> <p>(4) Kept at $25 \pm 2^\circ C$ for 5 hours;</p> <p>(5) Discharge: 0.2C constant current discharge to cut-off voltage $\leq 2.5V$ at $25\pm 2^\circ C$, to obtain the residual capacity;</p> <p>(6) Charge: 0.5C constant current charge to 4.2V followed by 4.2V constant voltage charge to cut-off current $\leq 0.01C$ at $25\pm 2^\circ C$; Discharge: 0.2C constant current discharge to cut-off voltage $\leq 2.5 V$ at $25\pm 2^\circ C$, to obtain the recovery capacity.</p> <p>(1) 充电: $25\pm 2^\circ C$ 下, 以 0.5C 恒流充电至 4.2V 后, 以 4.2V 恒压充电至电流$\leq 0.01C$; 放电: $25\pm 2^\circ C$ 下, 以 0.2C 恒流放电至截止电压$\leq 2.5V$, 获得初始容量;</p> <p>(2) 充电: $25\pm 2^\circ C$ 下, 以 0.5C 恒流充电至 4.2V 后, 以 4.2V 恒压充电至电流$\leq 0.01C$;</p> <p>(3) 于 $60\pm 2^\circ C$ 下存储 7 天;</p> <p>(4) 于 $25\pm 2^\circ C$ 下放置 5 小时;</p> <p>(5) 放电: $25\pm 2^\circ C$ 下, 以 0.2C 恒流放电至截止电压$\leq 2.5V$, 获得残余容量;</p> <p>(6) 充电: $25\pm 2^\circ C$ 下, 以 0.5C 恒流充电至 4.2V 后, 以 4.2V 恒压充电至电流$\leq 0.01C$; 放电: $25\pm 2^\circ C$ 下, 以 0.2C 恒流放电至截止电压$\leq 2.5V$, 获得恢复容量。</p>	<table border="1"> <thead> <tr> <th>Capacity 容量</th> <th>Relative Capacity 相对容量比</th> </tr> </thead> <tbody> <tr> <td>Residual capacity 残余容量</td> <td>$\geq 85\%$</td> </tr> <tr> <td>Recovery capacity 恢复容量</td> <td>$\geq 90\%$</td> </tr> <tr> <td>Initial capacity 初始容量</td> <td>100%</td> </tr> </tbody> </table>	Capacity 容量	Relative Capacity 相对容量比	Residual capacity 残余容量	$\geq 85\%$	Recovery capacity 恢复容量	$\geq 90\%$	Initial capacity 初始容量	100%
			Capacity 容量	Relative Capacity 相对容量比							
Residual capacity 残余容量	$\geq 85\%$										
Recovery capacity 恢复容量	$\geq 90\%$										
Initial capacity 初始容量	100%										

5.5 Environmental and safety characteristics 环境适应性能和安全性能

This spec manual is the enterprise standard of ZhengZhou BAK Battery Co., Ltd. Without authorization, any pirate or circulation is prohibited.

本规格书为郑州比克电池有限公司企业标准, 未经授权, 禁止翻印、传播。

Document No	P/PR03/PB-D-N18650CP-ZZ-SP	Version	A/02	Page	7/14
-------------	----------------------------	---------	------	------	------

NO. 序号	ITEM 测试项目	CRITERION 性能标准	TESTING METHOD 测试条件与方法	STANDARD 标准
5.5.1	Vibration 振动性能	No fire, No explosion, No leakage, The maximum mass loss $\leq 0.1\%$ 电芯不起火、不爆炸、不漏液, 最大质量损失 $\leq 0.1\%$	After standard fully charge, cell shall be attached to a vibration table directly and subjected to vibration that consists of 10 Hz to 55 Hz to 10 Hz at the speed of 1Hz/min in 90~100mins. The total excursion of the vibration is 0.8mm (0.060 inches). The cell shall be vibrated in each direction along axis of the cylinder and the vertical directions of axis of the cylinder. 将满电电芯放在振动实验台上, 在 90~100mins 由 10 Hz 到 55 Hz 再到 10Hz 以 1Hz/min 的速率变化, 振幅为 0.8mm (0.060 英寸) 进行振动实验。电芯在电芯的轴向和与电芯轴向垂直的两个方向上振动。	UL1642
5.5.2	Drop test 跌落测试	No fire, No explode 电芯不起火、不爆炸	The cell is charged following the standard charge method; The cells is dropped three times from a height of 1.0 m onto a concrete floor, to obtain impacts in random orientations, at $25^{\circ}\text{C} \pm 2^{\circ}\text{C}$; Observation of 1 h. 将电芯按标准充电方式充满电; $25^{\circ}\text{C} \pm 2^{\circ}\text{C}$ 下, 将电芯从 1.0m 高度处自由跌落三次到水泥地面上, 以此获得随机方向的冲击; 观察 1h。	IEC62133
5.5.3	Overcharge test 过充测试	No fire, No explode 电芯不起火、不爆炸	The cell is discharged following the standard discharge method. Apply a 8.4V power supply and a 2C charge current for 24hrs. 电芯按照标准放电方式放电完后, 采用 2C 电流 8.4V 电压持续充电 24 小时。	UN38.3
5.5.4	Forced Discharge test 强制放电测试	No fire, No explode 电芯不起火、不爆炸	Cell shall first be discharged according to standard discharge method, then the cell is subjected to a reverse charge at 1C for 90 min at $25 \pm 2^{\circ}\text{C}$ 电芯按照标准充电方式放电后, $25 \pm 2^{\circ}\text{C}$ 条件下以 1C 反向充电 90minutes。	IEC62133
5.5.5	130°C hot oven test 130°C 热箱测试	No fire, No explode 电芯不起火、不爆炸	The cell is charged following the standard charge method. After charging the cell is put in the oven. And then the oven temperature will be ramped at 5°C per minute to 130°C and held at 130°C . When the temperature of the cell reach 130°C , the cell is maintained in the 130°C oven for a maximum of 30 minute or until a fire or explosion is obtained, whichever comes first. 电芯按照标准充电方式充满电后, 将电芯放进热箱里, 然后将热箱按 $5^{\circ}\text{C}/\text{min}$ 升温到 130°C , 当电芯的温度也达到 130°C 时, 电芯在热箱 130°C 环境下保持 30 分钟或者电芯起火爆炸为止。	GB31241

Document No	P/PR03/PB-D-N18650CP-ZZ-SP	Version	A/02	Page	8 / 14
-------------	----------------------------	---------	------	------	--------

5.5.6	Crush test 挤压测试	No fire、No explode 电芯不起火、不爆炸	<p>After charging a cell following the standard charge method, the cell shall be crushed between two flat surfaces. The direction of the crushing force shall be vertical to axis of the cylinder. The crushing force is to be applied by a hydraulic ram with a 32mm diameter piston. Crushing force is approximately 13 KN. Once the maximum pressure has been obtained it is to be released.</p> <p>电芯按照标准充电方式充满电后，放在两个平整的表面进行挤压测试，压力器必须施加一个与圆柱电芯轴向垂直的力，平压于电芯。采用 32 mm 直径的液压活塞，所用压力为 13 KN，一旦达到最大压力值，即释放压力。</p>	UL1642
5.5.7	Short circuit test at room temperature 室温短路测试	No fire、No explode 电芯不起火、不爆炸	<p>Cell shall first be charged according to standard charge method, and then cell is to be short-circuited by connecting the positive and negative terminals of the cell with copper wire having a maximum resistance load of $80 \pm 20\text{m}\Omega$. This test is done at room temperature. Monitor the cell temperature while testing. The cell is continuously discharged until the cell case temperature has returned to be 10°C less than peak temperature.</p> <p>电芯按照标准充电方式充满电后，在室温进行短路实验，用铜线短路其正负极(线路总电阻 $80\pm 20\text{m}\Omega$)，实验过程中监视电芯温度变化，当电芯温度下降到比峰值低 10°C 时，结束实验。</p>	UL1642
5.5.8	Short circuit test at 55°C 55°C 短路测试	No fire、No explode 电芯不起火、不爆炸	<p>Cell shall first be charged according to standard charge method, and then cell is to be short-circuited by connecting the positive and negative terminals of the cell with copper wire having a maximum resistance load of $80 \pm 20\text{m}\Omega$. This test is done at $55 \pm 5^\circ\text{C}$. Monitor the cell temperature while testing. The cell is continuously discharged until the cell case temperature has returned to be 10°C less than peak temperature.</p> <p>电芯按照标准充电方式充满电后，在 $55 \pm 5^\circ\text{C}$ 进行短路实验，用铜线短路其正负极(线路总电阻 $80\pm 20\text{m}\Omega$)，实验过程中监视电芯温度变化，当电芯温度下降到比峰值低 10°C 时，结束实验。</p>	UL1642

Document No	P/PR03/PB-D-N18650CP-ZZ-SP	Version	A/02	Page	9/14
-------------	----------------------------	---------	------	------	------

5.5.9	Low Pressure test 低气压测试	No fire, No explosion, No leakage, The maximum mass loss $\leq 0.1\%$ 电芯不起火、不爆炸、不漏液, 最大质量损失 $\leq 0.1\%$	Cell shall first be charged according to standard charge method, and then cell is to be stored at an absolute pressure of 11.6 kPa for six hours at ambient temperature. 电芯按照标准充电方式充满电后, 在绝对气压等于 11.6 kPa 的室温条件下存储 6h。	UL1642
Note 备注	All above safety tests will be conducted at $25^{\circ}\text{C} \pm 2^{\circ}\text{C}$ except where specified differently. Use proper ventilation with protective equipment. 除特殊说明, 以上所有安全测试均应在 $25^{\circ}\text{C} \pm 2^{\circ}\text{C}$ 通风橱中, 且附带有保护装置的条件下进行。			

6 Package picture 包装图片



Small box

小箱

Big box

大箱

Pallet

货板

(100pcs cells in a small box, 2 small boxes in a big box)

(每小箱装 100 只电芯, 1 个大箱装 2 个小箱)

7 Shipment 出货

The cell shall be shipped in voltage range of 3.5 ~ 3.8 V or in accordance with customers' requirement. The remaining capacity before charging shall be changed depending on the storage time and conditions.

单体电芯按 3.5 ~ 3.8 V 的充电电压或客户要求出货, 电芯出货后充电前的剩余容量取决于储存时间和条件。

8 Warranty 质量保证

The Warranty period of cell is made according to business contract. However, even though the problem occurs within this period, BAK won't replace a new cell for free as long as the problem is not due to the failure of BAK manufacturing process or is due to customers' abuse or misuse.

自出货之日起, 电芯的保质期依合同而定。但是, 在此期限内, 如果非比克公司的制程原因, 而是

This spec manual is the enterprise standard of ZhengZhou BAK Battery Co., Ltd. Without authorization, any pirate or circulation is prohibited.

本规格书为郑州比克电池有限公司企业标准, 未经授权, 禁止翻印、传播。

Document No	P/PR03/PB-D-N18650CP-ZZ-SP	Version	A/02	Page	10 / 14
--------------------	----------------------------	----------------	------	-------------	---------

客户的误用造成的电芯质量问题，比克公司不承诺免费更换。

BAK will not be responsible for the trouble caused by handling in violation of cautions in instructions.

比克公司对违反安全守则操作所产生的问题不承担任何责任。

BAK will not be responsible for the trouble caused by matching electric circuit, cell pack and charger.

比克公司对与电路、电池组、充电器搭配使用所产生的问题不承担任何责任。

BAK will not be responsible for any defect of cells caused during assembling after acceptance.

出货后客户在电芯组装过程中产生的不良电芯不在比克公司质量保证的范围之列。

9 Storage and shipment requirement 存储及运输要求

Item 项目	Conditions 环境	Permissible time 允许时间
Storage environment 储存环境	-20°C~ 60°C, 60% RH Max	Less than 1 month 少于 1 个月
	-20°C~ 45°C, 60% RH Max	Less than 3 months 少于 3 个月
	-20°C~ 25°C, 60% RH Max	Less than 1 year 少于 1 年
About long time storage: If the cell needs to be stored for a long time, the cell's storage voltage should be 3.5 ~ 3.8 V. Also, it is recommended to charge the cell every six months. 关于长期存储: 若电池需长期存储, 电池的存储电压应该为 3.5 ~ 3.8 V。同时, 建议每 6 个月对电池进行充电。		

10 Warning and cautions in handling the lithium-ion cell 电芯使用时警告事项及注意事项

Lithium-ion rechargeable cells subjected to abuse can cause damage to the cell and/or personal injury. Please read and observe the standard cell precautions below before utilization.

滥用锂离子充电电芯可能会造成电芯的损害或人身的伤害.在使用锂离子充电电芯以前,请仔细阅读以下的安全守则:

Note 1. The customer is required to contact BAK in advance, if and when the customer needs other applications or operating conditions not described in this document.

注释 1. 如果客户需要其它应用程序或本文档中描述之外的操作条件, 客户需要提前联系比克。

Note 2. BAK will take no responsibility for any accident when the cell is used under other conditions not described in this document.

注释 2. 在该文件说明的条件之外使用该电芯而产生的事故, 比克公司不承担任何责任。

Warnings 警告

To prevent the possibility of the cell from leaking, heating, explosion, please observe the following

Document No	P/PR03/PB-D-N18650CP-ZZ-SP	Version	A/02	Page	11 /14
-------------	----------------------------	---------	------	------	--------

precautions: (It should be indicated especially in manual or instruction for users.)

危险警告：（应在使用说明手册或说明书中，特别注明）为防止电池可能发生泄漏，发热，爆炸，请注意以下预防措施：

1	Do not use and leave the cell near a heat source such as fire or heater. 禁止将电芯在热高温源旁，如火，加热器等旁边使用和留置。
2	Do not use or leave the cell under the blazing sun (or in heated car by sunshine). 不要将电芯放置在太阳光直射的地方。
3	Do not use or leave the cell at very high temperature conditions (e.g., strong direct sunlight or a vehicle in extremely hot conditions). Otherwise, it can overheat or catch fire or its performance will be degenerate and its service life will be decreased. 禁止在高温下（直热的阳光下或很热的汽车中）使用或放置电池，否则可能会引起电池过热，起火或功能失效，寿命减短。
4	Do not short circuit, over-charge or over-discharge the cell. 不要将电芯短路,过充或过放。
5	Don't immerse the cell in water and seawater. Please put it in cool and dry environment if no using. 严禁将电池浸入海水或水中，保存不用时，应放置在阴凉干燥的环境中。
6	Don't reverse the positive and negative terminals 严禁颠倒正负极使用电池。
7	Do not disassemble or modify the cell. 不要拆卸或修整电芯。
8	Do not transport or store the cell together with metal objects such as necklaces, hairpins, coins, etc. 禁止将电池与金属，如发夹，项链等一起运输或贮存。
9	Make sure the cell is not with conspicuous damage or deformation. 不要使电芯受到明显的损害或变形。
10	Don't connect the cell to an electrical outlet directly. 严禁将电芯直接插入电源插座。
11	If the cell leaks and the electrolyte splashes into the eyes, rinse the eyes with clean running water immediately for at least 15 minutes, and go to hospital for treatment if necessary. 如果电芯发生泄露，电解液进入眼睛，请立即用清水冲洗眼睛至少 15 min，必要时请立即前往医院接受治疗。
12	Mixed use of cells of different types is not allowed. 禁止与液态锂离子或不同型号的锂电池混合使用。
13	Keep the cell away from babies.

This spec manual is the enterprise standard of ZhengZhou BAK Battery Co., Ltd. Without authorization, any pirate or circulation is prohibited.

本规格书为郑州比克电池有限公司企业标准，未经授权，禁止翻印、传播。

Document No	P/PR03/PB-D-N18650CP-ZZ-SP	Version	A/02	Page	12 / 14
--------------------	----------------------------	----------------	------	-------------	---------

	电池应远离小孩。
14	Do not directly solder the cell and pierce the cell with a nail or other sharp object 禁止直接焊接电池和用钉子或其它利器刺穿电池。
15	Do not strike, throw or trample the cell. 禁止敲击或抛掷，踩踏电池等。
16	Use the cell charger specifically for that purpose when charging. 充电时请选用锂离子电池专用充电器。
17	Please separate cells of different electrochemical systems from one another when disposing of secondary cells. 二次电池处理时，请将电池和其他电化学体系的产品分开。
18	Clean the terminals with a dry cloth before use if the cell terminals are dirty. Otherwise power failure or charge failure may occur due to the poor connection with the instrument. 如果电池弄脏，使用前应用干布抹净，否则可能会导致接触不良功能失效。
19	Cells should be removed from the device or charger immediately and not used again if they are over heat, give off odor, discolor or deform, or appear abnormally in any way during use, charging and storage. 如果电池发出异味，发热，变色，变形或使用，贮存，充电过程中出现任何异常现象，立即将电池从装置或充电器中移离并停用。
20	The cell replacement shall be done only by either cell supplier or device supplier instead of the user. 更换电芯应由电芯供应商或设备供应商完成，用户不得自行更换。
21	Please tape the terminals to insulate cells before discarding them in case of fire and explosion. 废弃电池之前应用绝缘纸包住电极，以防起火、爆炸。
22	Do not use cells in strong electrostatic and magnetic occasions, otherwise, it can cause safety problems easily. 禁止在强静电和强磁场的地方使用，否则易带来不安全的隐患。
23	Use of damaged cells is not permitted. 禁止使用已损坏的电芯。
24	Make sure package designing will not cause cell damages. 电池外壳设计和包装禁止损伤电池。
25	Cell packing should be conducted strictly according to level range, any misuse of different levels should not be permitted. 电池配组时需严格按等级执行，不能跨等级成组。
26	Disassembling cells from pack or module is not permitted unless under the guidance of professional technicians. 严禁将电池从电池包或电池模组中拆卸，除非在专业技术人员的指导下进行。

Document No	P/PR03/PB-D-N18650CP-ZZ-SP	Version	A/02	Page	13 / 14
-------------	----------------------------	---------	------	------	---------

11 Restriction of hazardous substances 有害物质控制要求

This model of lithium-ion cell is in accordance with our company's request of "The hazardous substances and material management standard" or customer's requirements.

本型号锂离子电芯符合本公司《有害物质与材料管理规范》要求或参照客户要求执行。

12 Contact information 联系方式

If you have any questions regarding the cell, please contact the following address:

如有疑问，请按以下地址联系：

1. ZHENGZHOU BAK BATTERY CO., LTD

The intersection 300meters West of Zhongxin Road & BAK Avenue, Zhongmu Country, Zhengzhou City, Henan, China. ZIP: 451450

Contact phone number: 0371-62033101

郑州比克电池有限公司

郑州市中牟县中兴路与比克大道交叉口向西 300 米 邮编 451450

联系电话：0371-62033101

2. SHENZHEN BAK POWER BATTERY CO., LTD

BAK Industrial Park on Kuichong Road, Dapeng District, Shenzhen. ZIP: 518119

Contact phone number: 0755-61886818

深圳市比克动力电池有限公司

深圳市大鹏新区葵涌街道比克工业园 邮编：518119

联系电话：0755-61886818

Document No	P/PR03/PB-D-N18650CP-ZZ-SP	Version	A/02	Page	14 /14
--------------------	----------------------------	----------------	------	-------------	--------

13 Revision history 修订履历

Version 版次	Change Content 修改内容	Page 页码	PIC 修改人	Date 修改日期
A/00	初版发行	全部	Xianwen Yi	2020-04-13
A/01	增加联系方式	13	Xianwen Yi	2020-04-22
A/02	修改常温循环评测制式 修改高温存储标准	6 8	Xianwen Yi	2021-01-28